



## AM/2.1000 Monoaxial MEMS DC Response Accelerometer

±2g range, 1000mV/g sensitivity

The AM range of accelerometers are MEMS (micro electro mechanical system) DC response voltage output devices for testing at low frequency vibration measurement from DC (0Hz) and above. They are single axis variable capacitance design and are available with a 2m integral cable fitted with a 7pin connector to suit the DJB DCM-03 MEMS signal conditioning unit or alternatively as bare wires.

Ideally suited to low frequency vibration applications including low level vibration where high sensitivity is required.

Due to their ability to measure DC response they can also be used to measure constant gravity application.

The AM/2.1000 has a range of ±2g and a sensitivity of 1000mV/g, we recommend using with DJB's MEMS signal conditioner the DCM-03

### Features:

- Operational frequency range DC to 200Hz
- Integral cable with 7 pin connector or pigtailed.
- DJB signal conditioner model DCM-03 available as an option
- Differential Capacitance operation
- Compact form and low mass
- Constant gravity measurement

### Applications:

- Auto/Aero structural body surveys
- Constant gravity measurements
- General vibration measurement
- Seismic vibration measurement
- Crash testing

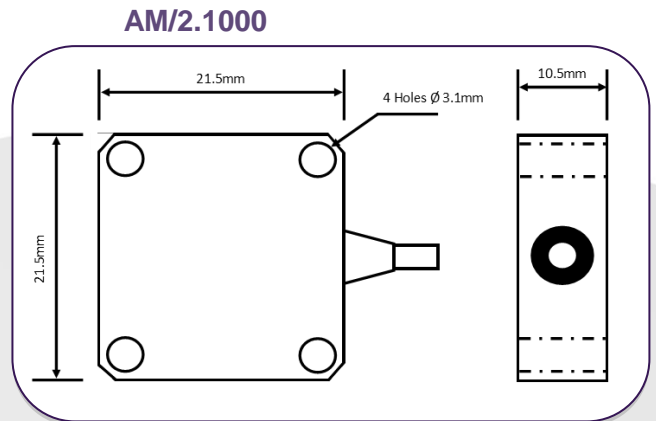

### Typical Temperature Response

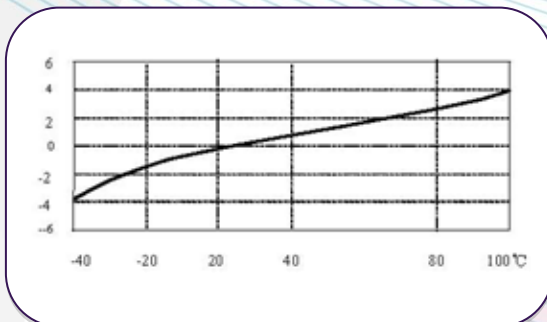

### Typical Frequency Response

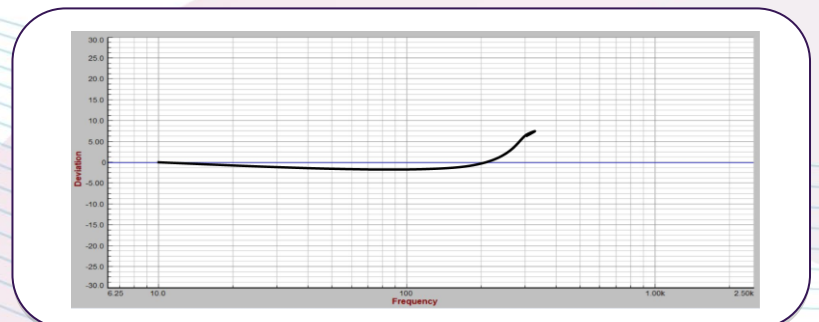

**Please note: For information and reference only. Data should not be used as pass / fail criteria for calibration purposes.**

### DJB Instruments (UK) Ltd

Finchley Avenue,  
Mildenhall, Suffolk IP28 7BG

Tel +44 (0)1638 712 288  
Email sales@djbinstruments.com  
Web www.djbinstruments.com

A UK company with UK-based manufacturing, assembly and calibration in-house.

DJB Iss.3.2019



FM11310



## AM/2.1000 Monoaxial MEMS DC Response Accelerometer

±2g range, 1000mV/g sensitivity

	Metric	Imperial
Sensitivity (20°C)	100.97mV/(m/s <sup>2</sup> ) ±10%	1000mV/g±10%
Measurement Range	±19.6m/s <sup>2</sup> pk	±2g pk
Transverse sensitivity	≤5%	
Frequency Range (±5%)	DC to 200 Hz	
Frequency Range (±10%)	DC to 300Hz	
Mounted Resonance Frequency	5,000 Hz	
Temperature Range	-40 to +85°C	-40 to +185°F
Temperature Sensitivity	0.1 mV/°C	
Shock limit (No Supply)	34323m/s <sup>2</sup>	±3,500g
Power Supply	+6 to +15 VDC	
Operating Current	≤5mA	
Offset Voltage	2.5±0.1VDC	
Noise(100Hz)	< 0.14mVrms	
Resolution	4mg (rms)	
Output impedance	< 100 Ω	
Weight (no cable)	22grams	0.78oz
Case material	Hard Anodized Aluminum	
Case sealing	Epoxy Resin	
Mounting	4 x Ø3.1mm holes	4 x Ø0.12inch holes
Integral Output Cable	2m	6.5ft
Cable Exit	Side	
Cable connector	7 pin connector (optional pigtailed)	
Size	21.5 x 21.5 x 10.5mm	0.84 x 0.84 x 0.41 inches
IP rating	IP65	

### Options:

- DCM-03 – 3 channel MEMS signal conditioning unit.
- Pigtail cable terminations

**Please note: For information and reference only. Data should not be used as pass / fail criteria for calibration purposes.**

### DJB Instruments (UK) Ltd

Finchley Avenue,  
Mildenhall, Suffolk IP28 7BG

Tel +44 (0)1638 712 288  
Email sales@djbinstruments.com  
Web www.djbinstruments.com

A UK company with UK-based manufacturing, assembly and calibration in-house.

DJB Iss.3.2019



FM11310