



AM/20.100 Monoaxial MEMS DC Response Accelerometer

±20g range, 100mV/g sensitivity

The AM range of accelerometers are MEMS (micro electro mechanical system) DC response voltage output devices for testing at low frequency vibration measurement from DC (0Hz) and above. They are single axis variable capacitance design and are available with a 2m integral cable fitted with a 7pin connector to suit the DJB DCM-03 MEMS signal conditioning unit or alternatively as bare wires.

Ideally suited to low frequency vibration applications including low level vibration where high sensitivity is required.

Due to their ability to measure DC response they can also be used to measure constant gravity application.

The AM/20.100 has a range of ±20g and a sensitivity of 100mV/g, we recommend using with DJB's MEMS signal conditioner the DCM-03

Features:

- Operational frequency range DC to 300Hz
- Integral cable with 7 pin connector or pigtailed.
- DJB signal conditioner model DCM-03 available as an option
- Differential Capacitance operation
- Compact form and low mass
- Constant gravity measurement

Applications:

- Auto/Aero structural body surveys
- Constant gravity measurements
- General vibration measurement
- Seismic vibration measurement
- Crash testing

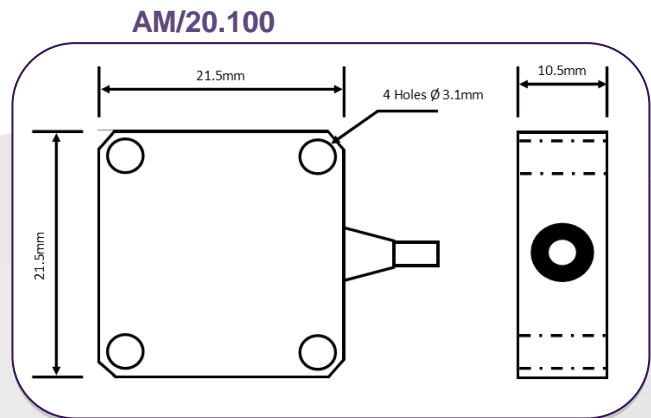

Typical Temperature Response

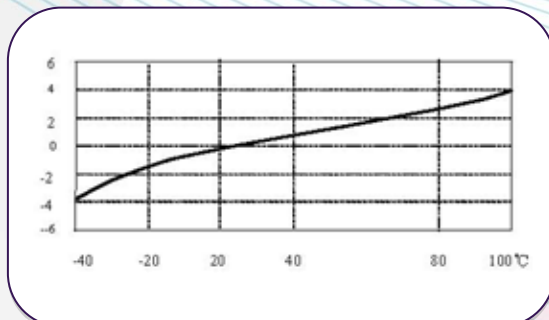

Typical Frequency Response

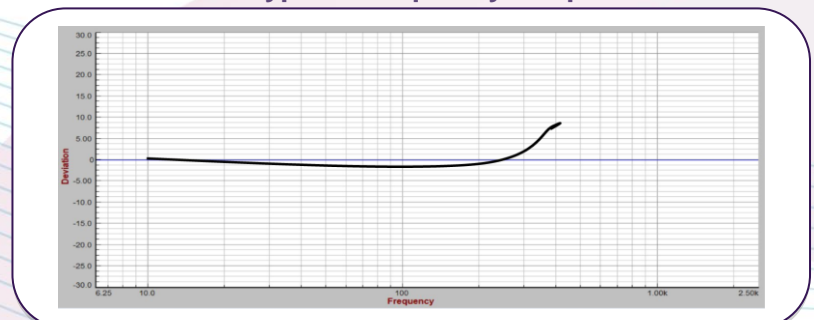

Please note: For information and reference only. Data should not be used as pass / fail criteria for calibration purposes

DJB Instruments (UK) Ltd

Finchley Avenue,
Mildenhall, Suffolk IP28 7BG

Tel +44 (0)1638 712 288
Email sales@djbinstruments.com
Web www.djbinstruments.com

A UK company with UK-based manufacturing, assembly and calibration in-house.

DJB Iss.3.2019



FM11310

AM/20.100 Monoaxial MEMS DC Response Accelerometer

±20g range, 100mV/g sensitivity



	Metric	Imperial
Sensitivity (20°C)	10.97mV/(m/s ²)±10%	100mV/g±10%
Measurement Range	±196.1m/s ² pk	±20g pk
Transverse sensitivity	≤5%	
Frequency Range (±5%)	DC to 300 Hz	
Frequency Range (±10%)	DC to 400Hz	
Mounted Resonance Frequency	5,000 Hz	
Temperature Range	-40 to +85°C	-40 to +185°F
Temperature Sensitivity	0.1 mV/°C	
Shock limit (No Supply)	34323m/s ²	±3,500g
Power Supply	+6 to +15 VDC	
Operating Current	≤5mA	
Offset Voltage	2.5±0.1VDC	
Noise(100Hz)	< 0.14mVrms	
Resolution	10mq (rms)	
Output impedance	< 100 Ω	
Weight (no cable)	22grams	0.78oz
Case material	Hard Anodized Aluminum	
Case sealing	Epoxy Resin	
Mounting	4 x Ø3.1mm holes	4 x Ø0.12inch holes
Integral Output Cable	2m	6.5ft
Cable Exit	Side	
Cable connector	7 pin connector (optional pigtailed)	
Size	21.5 x 21.5 x 10.5mm	0.84 x 0.84 x 0.41 inches
IP rating	IP65	

Options:

- DCM-03 – 3 channel MEMS signal conditioning unit.
- Pigtail cable terminations

Please note: For information and reference only. Data should not be used as pass / fail criteria for calibration purposes

DJB Instruments (UK) Ltd

Finchley Avenue,
Mildenhall, Suffolk IP28 7BG

Tel +44 (0)1638 712 288
Email sales@djbinstruments.com
Web www.djbinstruments.com

DJB Iss.3.2019



A UK company with UK-based manufacturing, assembly and calibration in-house.

FM11310